

MOD ZILLA

SHORT FRAME ROUND MODULE OPENER

U.S. PATENT APPROVED 9/21/11
14 CLAIMS AWARDED

MODEL RMO-20SF

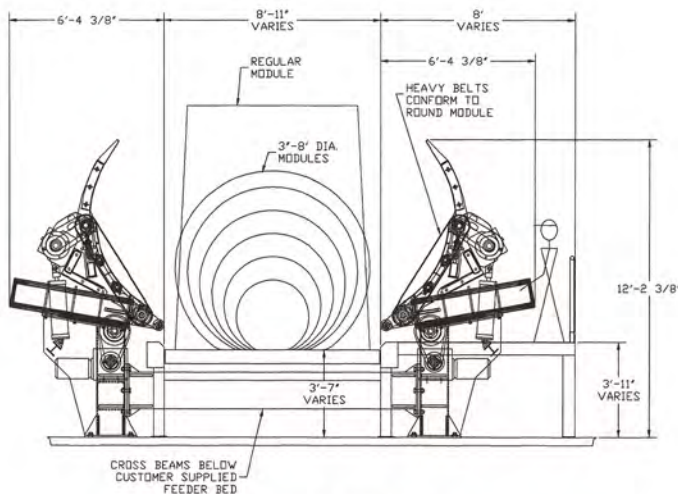

OPENED INFEED END VIEW
CONVEYS ROUND MODULE IN OR
REGULAR MODULE THROUGH

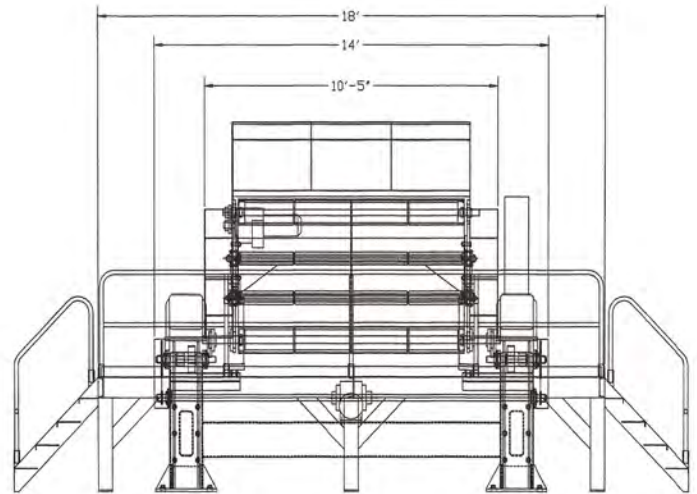

OPENED
SIDE VIEW

ADVANTAGES:

- *Single Operator*
- *Compact design fits in less space*
- *No hydraulics*
- *Requires no special foundation*
- *Fits under most feeder beds*
- *Heavy duty belts conform to round modules thus keeping cotton dense yielding consistent feed rates*
- *Belts tilt up in feed position to form side walls preventing spillage*
- *Heavy duty frame*
- *Blowout system prevents cotton build-up underneath belts*
- *Priced well below competitors*
- *Simple to install & operate*

SPECIFICATIONS:

- *Driven by (4) 5 HP gear motors & (4) 8" DIA air cylinders @ 75 PSI*
- *Optional RFID tag reader locates inner tail virtually eliminating the possibility of plastic contamination*
- *80-100 BPH capacity*
- *Belt Safety factor = 10 to 1*
- *Gin Friendly with Standard Components made in the USA*

COTTON MACHINE WORKS, LLC

Tel: (229) 273-1374 Cell: (229) 938-4670 E-Mail: c990@bellsouth.net
www.cottonmachineworks.com

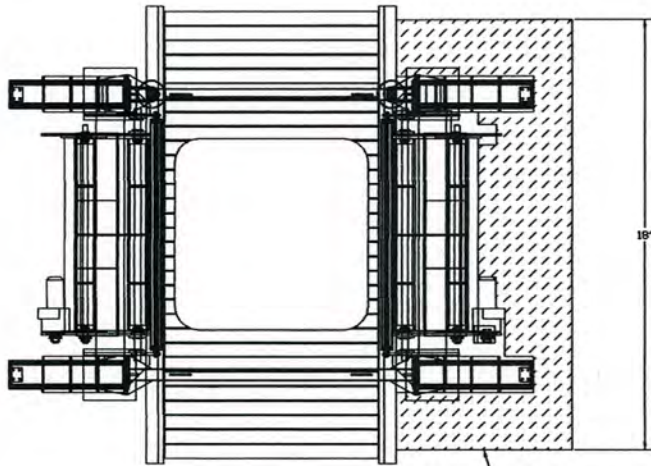

**OPENED TOP VIEW
WITH MODULE IN PLACE**

OPTIONAL OPERATOR'S
PLATFORM, OPEN SPACE
DENOTED BY CROSSES

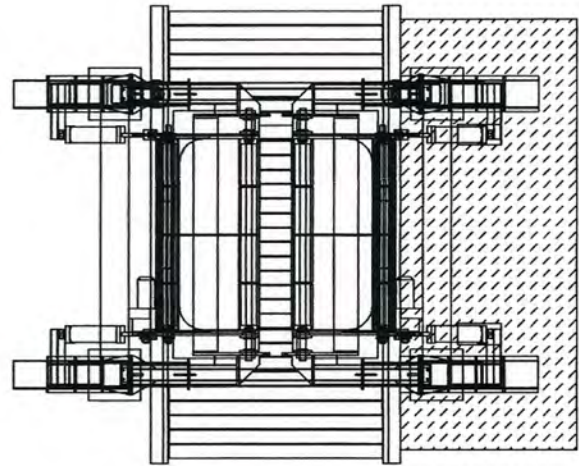

**CLOSED TOP VIEW
WITH MODULE LIFTED**

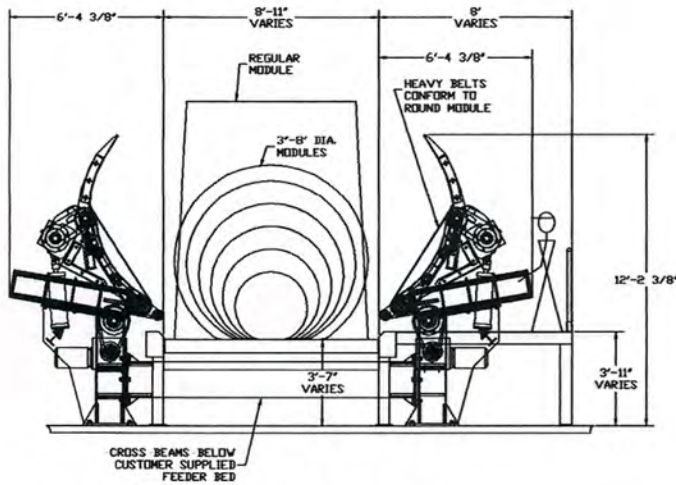

**OPENED INFED END VIEW
CONVEYS ROUND MODULE IN OR
REGULAR MODULE THROUGH**

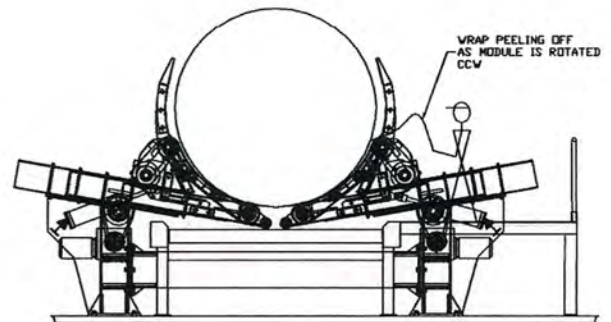

**CLOSED END VIEW WITH MODULE LIFTED
ROTATE CW & SCAN FOR INNER TAIL, STOP,
MANUALLY SLIT COVER THRU SLOT IN BACK
STOP. & ROTATE CCW TO REMOVE**

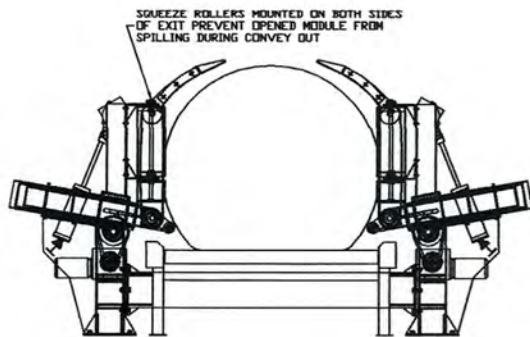

**EXIT END VIEW
OPEN WITH BELTS @90°
TO CONVEY MODULE OUT**

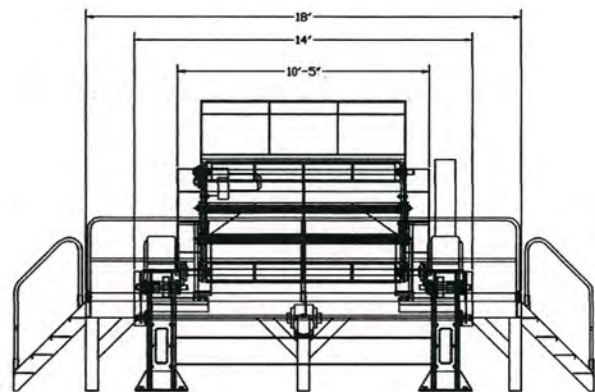

**OPENED
SIDE VIEW**

COTTON MACHINE WORKS, LLC

Tel: (229) 273-1374 Cell: (229) 938-4670 E-Mail: c990@bellsouth.net

www.cottonmachineworks.com